



**ARTMATCH**  
IN EVERY STORE

**COSMETICS &  
DETERGENTS  
DISPLAYS**



## HISTORY

Since 1998, we are providing high quality and cost-efficient solutions for display designs. Our continuous development based on innovation, consistency and dedication made us a trustworthy European partner in the retail environment.

## MISSION

Creativity and flexibility define us, as we are highly adaptable to our customers' needs. Our main focus is to come up with customised, versatile and up-to-date solutions that will significantly improve the shopping experience.

Our aim is to make customers sell better.

The question is:

**Do you want to sell better?**





**In this fast-paced world, we choose minimalism.**

People are tired of seeking solutions. That's why we bring the solutions to them by creating intuitive and accessible displays.

Simple is attractive - starting from this premise we manage to create modern and clean designs that will stand out from the crowd.

With over 20 years of experience in custom retail display creation, ARTMATCH works with a dedicated and skilled team helping its customers sell better.



## VACUUM-FORMED TRAYS

**Serve your customers wisely.**

These trays will not only make your product visible, but they are also the most effective way to use and organize the retail space.

### **Characteristics:**

- Made of PVC or PS film
- Various sizes available



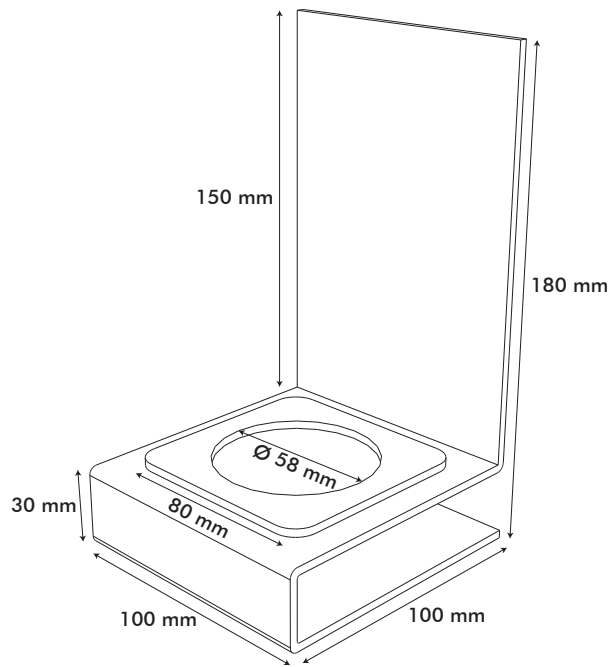

## PLEXIGLASS PRODUCT HIGHLIGHTER

**An outstanding product needs a tailor-made presentation.**

No time to despair. We got your back! This product highlighter will fit your product like a glove and it will accentuate all its qualities.

### **Characteristics:**

- Made of plexiglass (different thicknesses)



# MAKEUP DISPLAY

## Innovation defines us

All we want is to make your product end up in peoples houses. Therefore, we adopt unique and creative ideas to make it happen. We got this!

### Characteristics:

- Made of plexiglass and personalized with gold stickers.

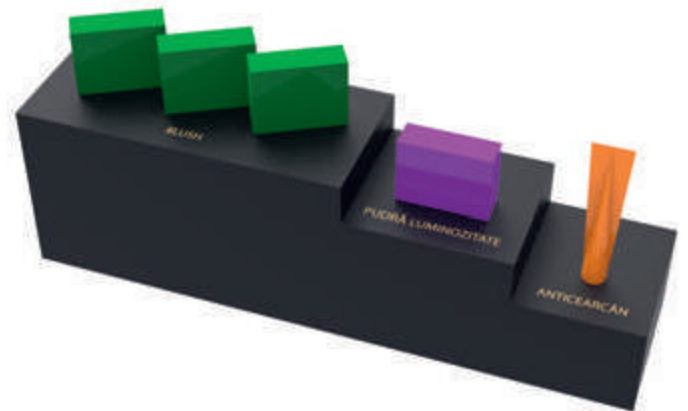

## TIERED COUNTER DISPLAY

Here's your last chance to grab your customers' attention.

But don't worry! This counter display is a real eye catcher that will showcase all the information needed to encourage the buying behaviour.

### Characteristics:

- Made of black HIPS foil and gold adhesive foil

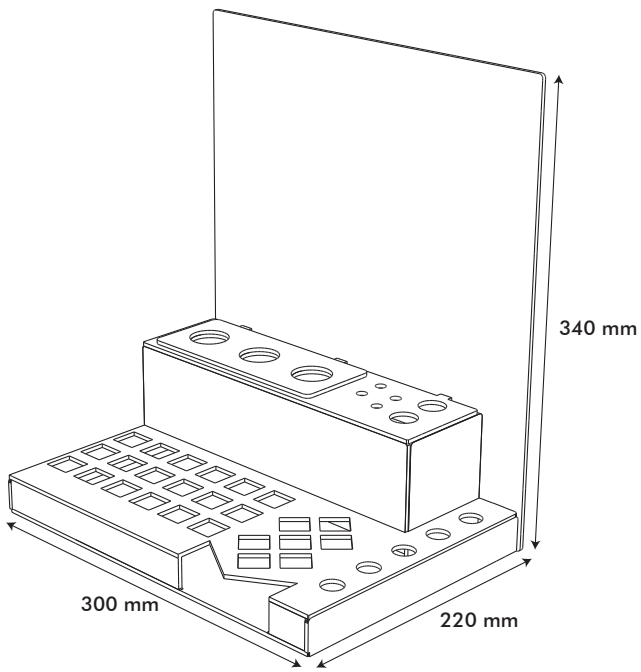

## TESTER DISPLAY

**Make sure your testers are visible and ready to use!**

This special dispenser can be easily fixed on the main shelf. Thus, your clients will be able to try out the scents without ruining the main product. Even though it's small, it really does its job seamlessly, making sure your clients will choose the product that fits them best.

### Characteristics:

- Made of HIPS SW with black core, clear PETG, glossy adhesive foil and G-clamp for fixing it on the shelf.

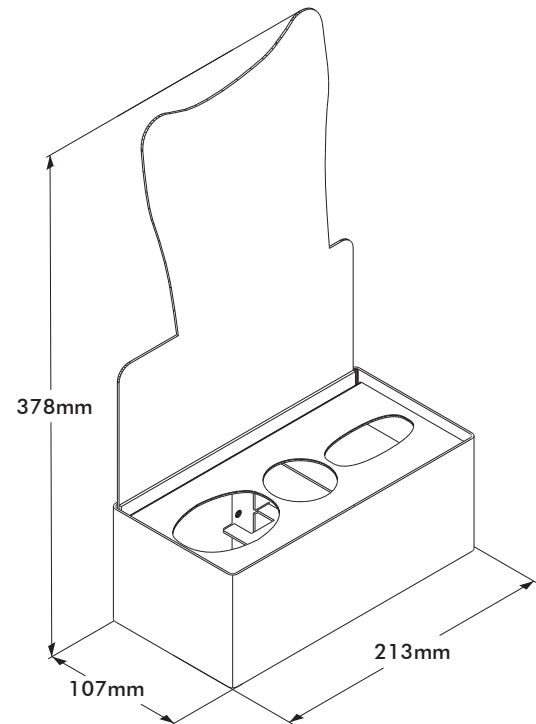





## DISPENSERS

Let's play with gravity and keep your products rolling.

This special dispenser is a compact, space saving solution, which facilitates stock rotation. Your products will keep rolling in the customers' shopping carts in no time.

### Characteristics:

- Made of corrugated cardboard (**Vanish Dispenser**) and clear PET film, HIPS SW with black core and G-clamp (**Dove and Rexona Dispenser**)



# MERCHANDISING STRIPS

**We will fit a stripe for you.**

Whether you want them with pockets, hooks or clamps, we have a solution that fits any packaging and weight.

## Characteristics:

- Made of various materials
- Some of them can be delivered flat



## CARDBOARD COUNTER DISPLAYS

**Better organized than sorry.**

Nothing compares to a display in which all the products are visible and in place. This counter display gives the smaller products a chance to get noticed too.

**Characteristics:**

- Made of corrugated cardboard



# CARDBOARD DISPLAYS FITTED ON CHEP PALLET

**It makes all the difference!**

A small detail like a display fitted on CHEP pallet can mark the border between: to sell or not to sell. Choose wisely!

## Characteristics:

- Made of corrugated cardboard



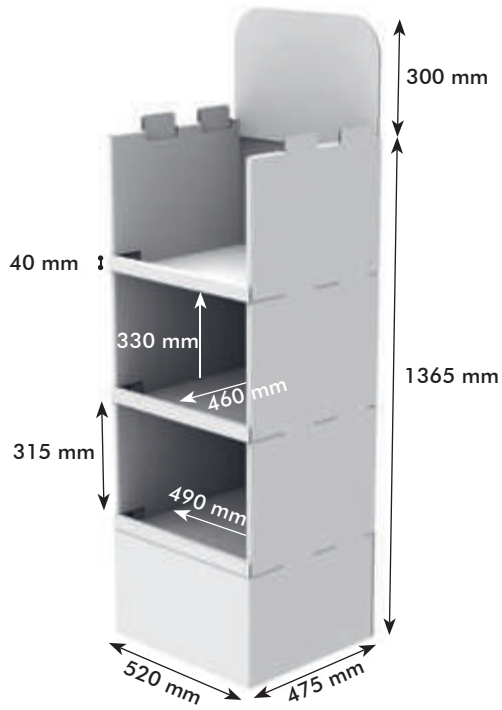

## MODULAR CARDBOARD DISPLAY

### Have you heard of the new game: Mix & MATCH?

This display is not only flat-delivered, lightweight and cost effective, but it's also a real challenge for your creativity. Are you in?

#### Characteristics:

- Made of corrugated cardboard



## SPECIAL DISPLAY DESIGNS

The roof is the limit, everything in between is our job

Special designs always challenge our team at different levels. No time for routine. We keep our minds busy trying to find the most creative ideas for you.

### Characteristics:

- Made of corrugated cardboard



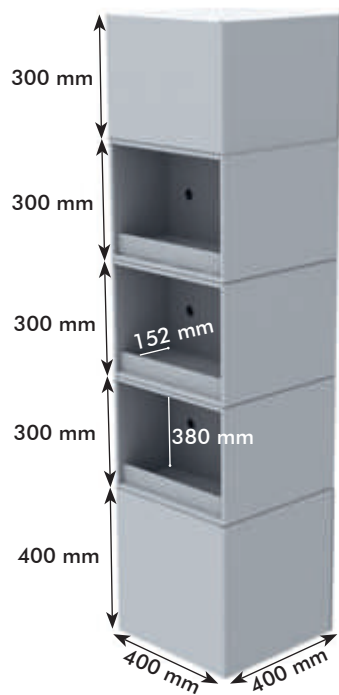

## CARDBOARD MODULAR DISPLAY

**Keep your brand playful and chic and your customers will love it!**

This display is specially designed for complex brands that have different types of products - just like yours. Make sure the display you choose to present your brand will outline its qualities seamlessly and that your products are visible from every angle of the store. Our display allows you to rotate the shelves as you like, thanks to its modular characteristics, so you can take the most out of it!

### Characteristics:

- Made of corrugated cardboard



## CARDBOARD PALLET DISPLAY

**It's a bird, it's a plane, it's Superman.  
No, it's a pyramid made of your  
products!**

This island display will be the center of attention of the whole store. Its size and shape will automatically make people curious and they will come closer to check it out. Your products will disappear in no time!

### Characteristics:

- Made of corrugated cardboard

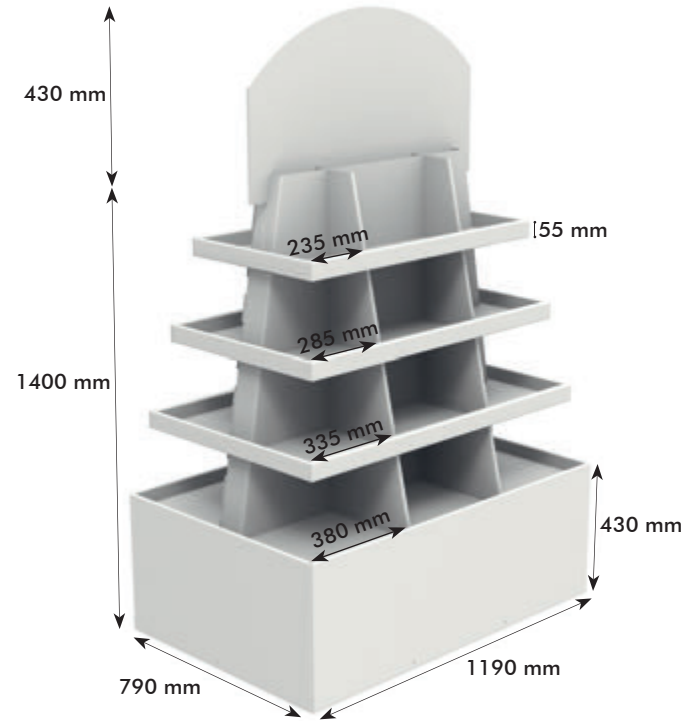



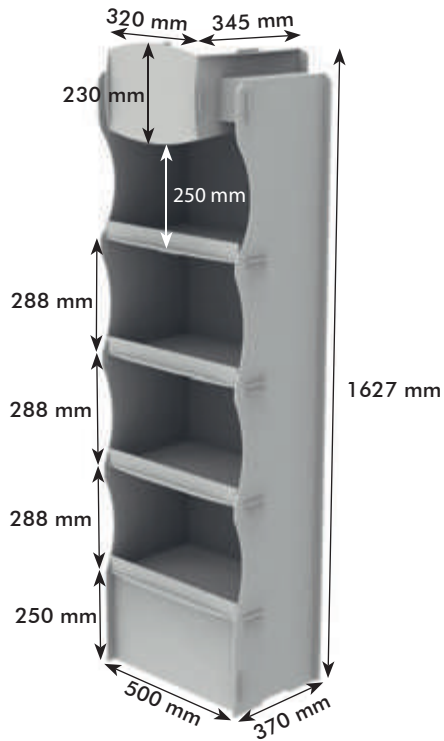

## HDF DISPLAY

### Elegance is key to everyone's hearts

This durable HDF display is not only a piece that will last a long time in a store, but it's also very chic and attractive due to its minimalist design. A simple presentation will always make your product shine brighter.

#### Characteristics:

- Made of HDF (High Density Fiberboard)



# FLAT PACK FLOOR DISPLAY

**Flat when packed, amazing when assembled.**

This display is any brand's dream as it comes flat packed, being incredibly easy to store and deliver and you can assemble it in a blink of an eye. However, all these practicalities are not affecting at all its eye-catching design that will bring your products in everyone's attention.

## Characteristics:

- Made of HDF (High Density Fiberboard)

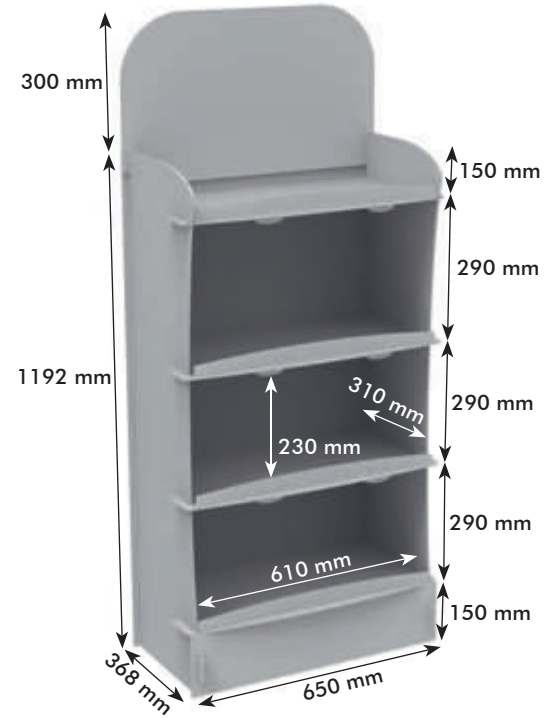

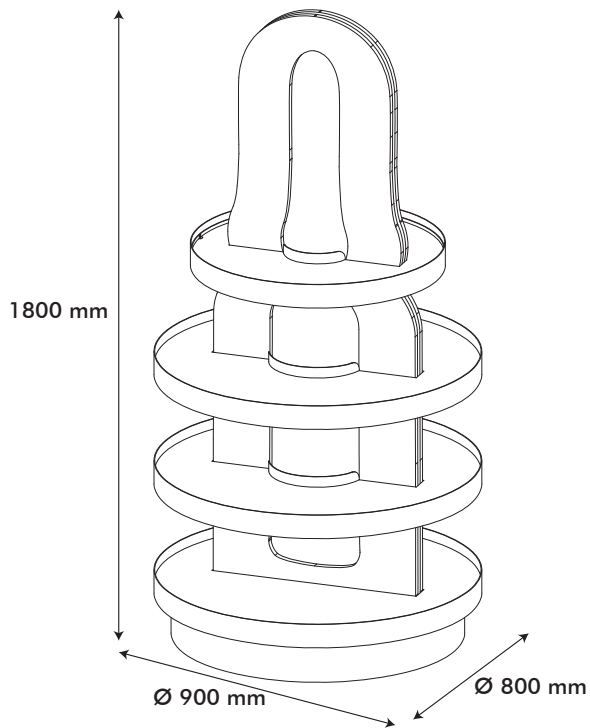

## WOODEN DISPLAY

### Go the extra mile.

This display may look simple, but in fact it has a complex mechanism that highlights your product in a very unique way.

### Characteristics:

- Made of laminated clipboard, PVC foam board, plexiglass, led strip and power supply



# SLIM METAL DISPLAY

**Slim down, fit better.**

You can fit your display now in really narrow spaces and yet you will still generate interest in your products.

## Characteristics:

- Made of steel sheet, rectangular steel pipe, PVC foam board
- UV printed

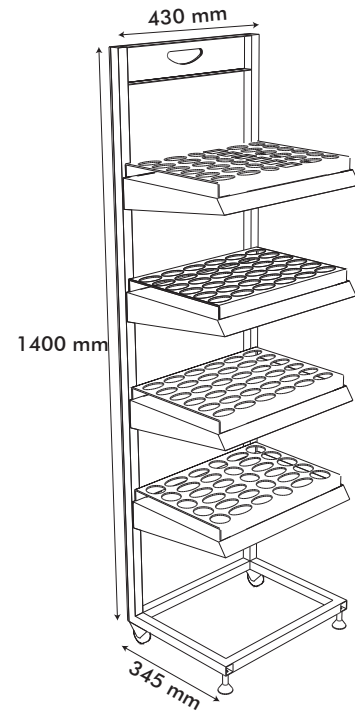

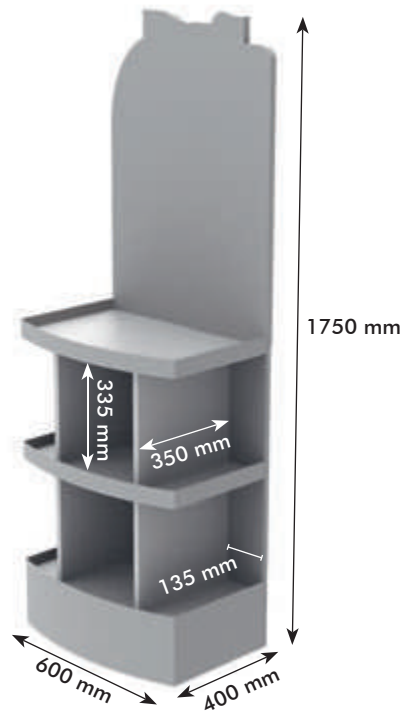

## CHIPBOARD DISPLAY

The “*piece de résistance*” - literally.

This display is perfect to bring into your clients' attention heavy products, such as detergents. Find a good place for it and let it do the job.

### Characteristics:

- Made of chipboard 18 mm, PVC foam board and PET film



# HDF CHRISTMAS TREE

## Christmas time all year around!

We wish that every time we see this HDF Christmas tree display that brings the holidays joy to everyone's soul. Bring beautiful Christmas memories to life to every person who passes by your products and you will be associated with positivity and good vibes.

### Characteristics:

- Made of HDF (High Density Fiberboard)

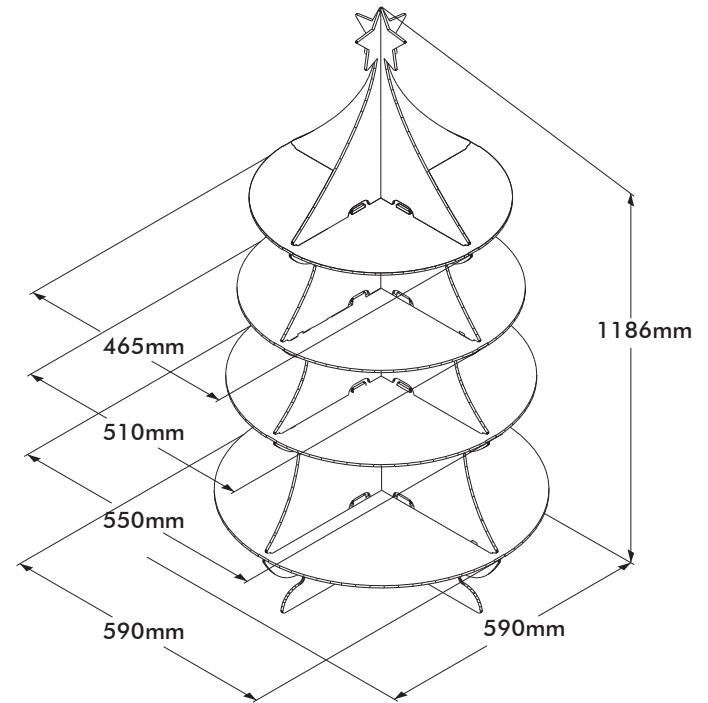

# FLAT PACK DISPLAYS

2020



Discover  
a new  
range of  
Displays!

**A**ll the displays are created and built by the guys in our design department in a cost saving mindset. **D**elivered in a way that minimizes the freight volume. **I**ndividually packed for better logistics, for easier storage and split deliveries. **I**llustrated easy-to-build assembly instructions.

**O**ur cool designers are looking forward for more challenges 😊

Visit our website for more information: [www.artmatch.net](http://www.artmatch.net).



## ROMANIA

Customer service, Design, Production  
Calea Șagului (DN59), KM 8+550 m,  
Platforma Incontro, Hala 4-7  
307221 Chișoda, Timiș, Romania  
Phone: +4 0256 305000  
info@artmatch.ro

## ROMANIA

Sales office  
Str. Ecaterina Teodoroiu 5  
010971 București, Sector 1, Romania  
Phone: +40 372783591  
bucuresti@artmatch.ro

## HUNGARY

Kagyló utca 1-3. 2092 Budakeszi  
Phone: +36 23-457145  
info@artmatch.hu

## SERBIA

Bulevar Arsenija Carnojevica 203/3,  
11070 Novi Beograd  
Phone: +381 11-3121575  
info@artmatch.rs

## GERMANY

Raiffeisenring 15, 46395 Bocholt  
Phone: +49 0 2871-2943758  
info@artmatch.net



**ARTMATCH**  
IN EVERY STORE