

**ARTMATCH**  
IN EVERY STORE

**PHARMA &  
COSMETICS  
DISPLAYS**



## HISTORY

Since 1998, we are providing high quality and cost-efficient solutions for display designs. Our continuous development based on innovation, consistency, and dedication made us a trustworthy European partner in the retail environment.

## MISSION

Creativity and flexibility define us as we are highly adaptable to our customers' needs. Our main focus is to come up with customised, versatile, and up-to-date solutions that will significantly improve the shopping experience. Our aim is to make customers sell better. The question is: Do you want to sell better?





## **VACUUM-FORMED TRAYS**

**Serve your customers wisely.**

These trays will not only make your product visible, but they are also the most effective way to use and organize the retail space.

### **Characteristics:**

- Made of PVC or PS film
- Various sizes available

# PLEXIGLASS PRODUCT HIGHLIGHTER

An outstanding product needs a tailor-made presentation.

No time to despair. We got your back! This product highlighter will fit your product like a glove and it will accentuate all its qualities.

## Characteristics:

- Made of plexiglass (different thicknesses)

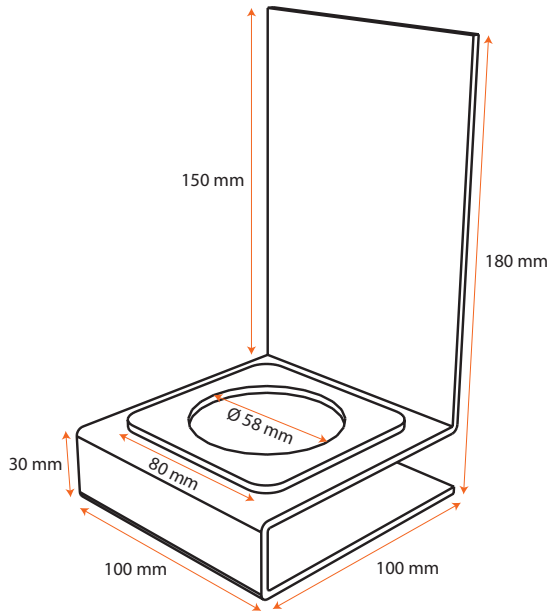

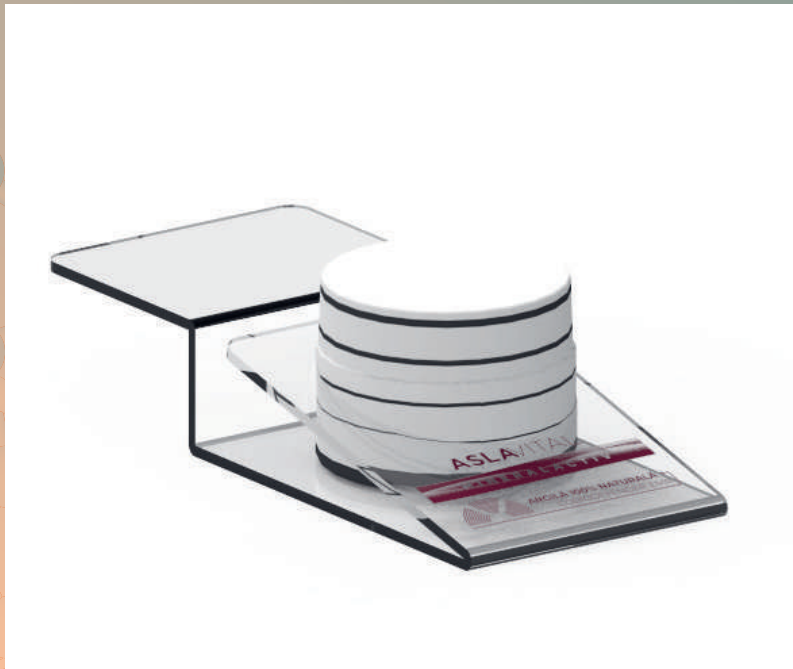
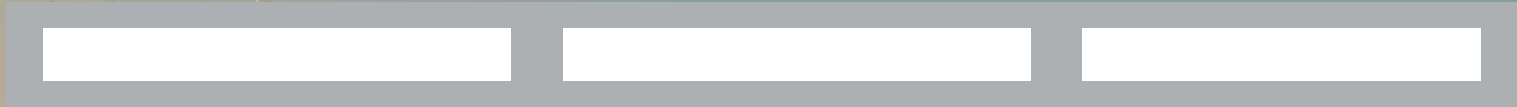
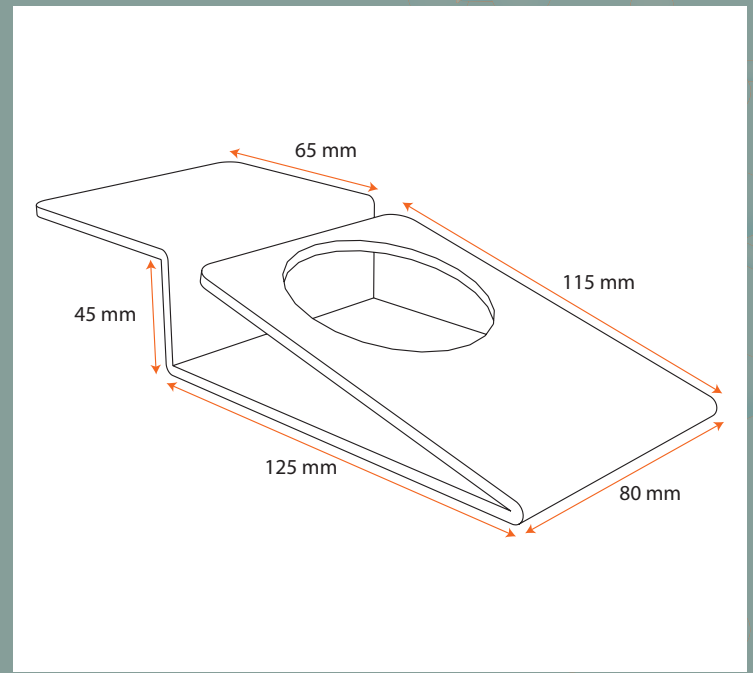
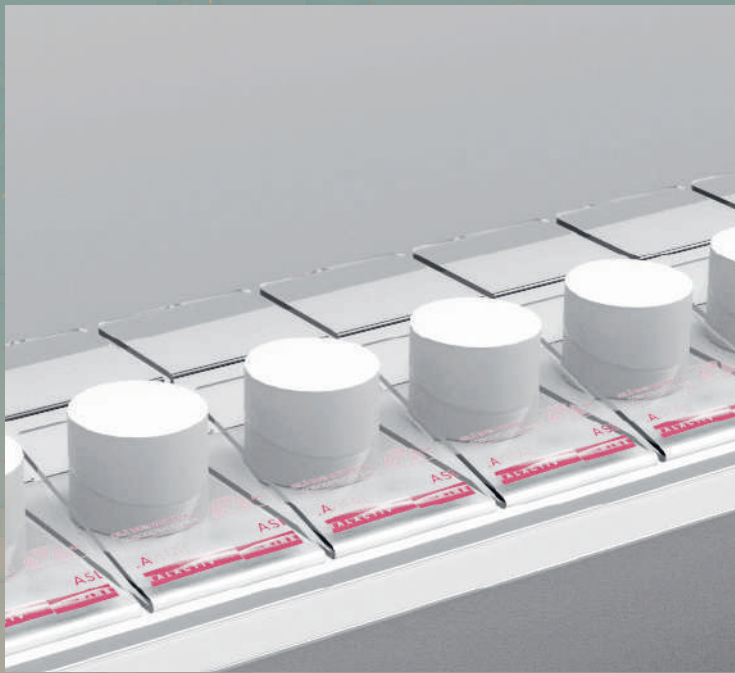

## PRODUCT HIGHLIGHTER

**Your clients will get attached to it!**

This solution impresses because of its mechanism that allows you to attach it to the edge of the shelves. Don't miss the chance to make your product be noticed in innovative and creative ways.

### **Characteristics:**

- Made of plexiglass

# COUNTER DISPLAY

Here's your last chance to grab your customers' attention.

But don't worry! This counter display is a real eye catcher that will showcase all the information needed to encourage the buying behaviour.

## Characteristics:

- Made of HIPS foil and gold autocolant
- Outer overall dimensions: 300x220x340 mm

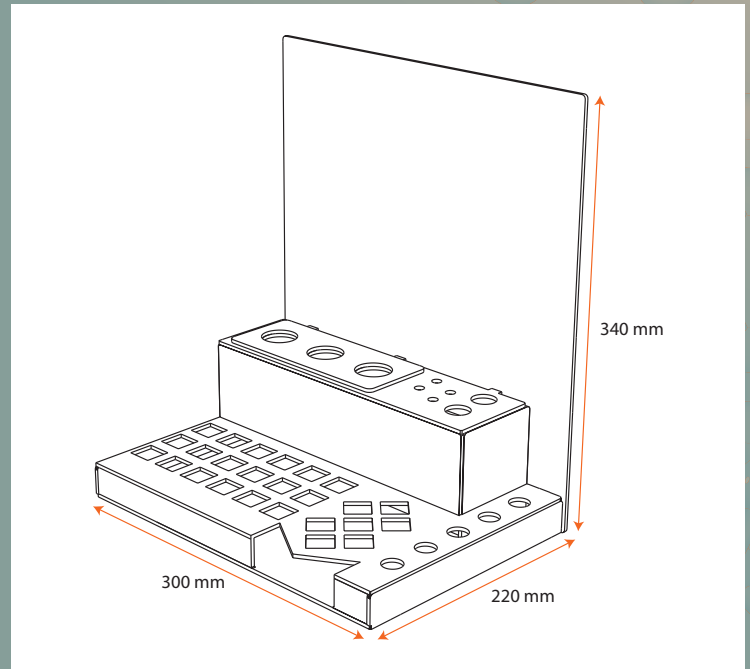
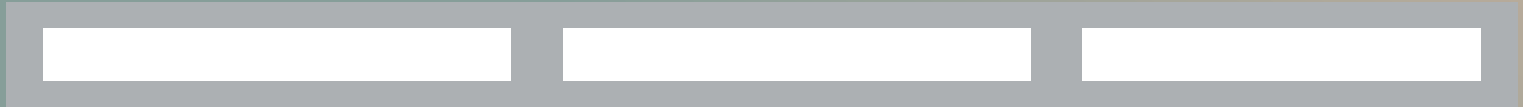
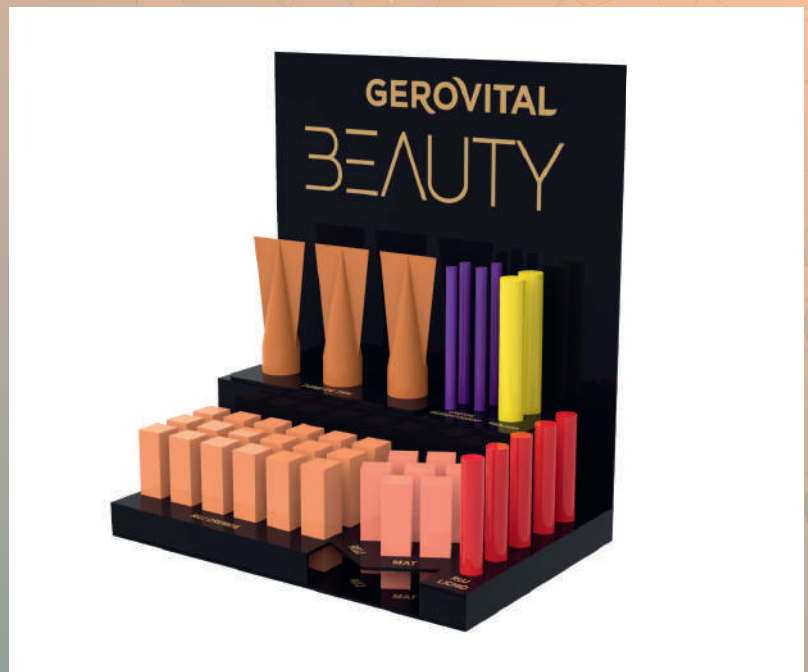

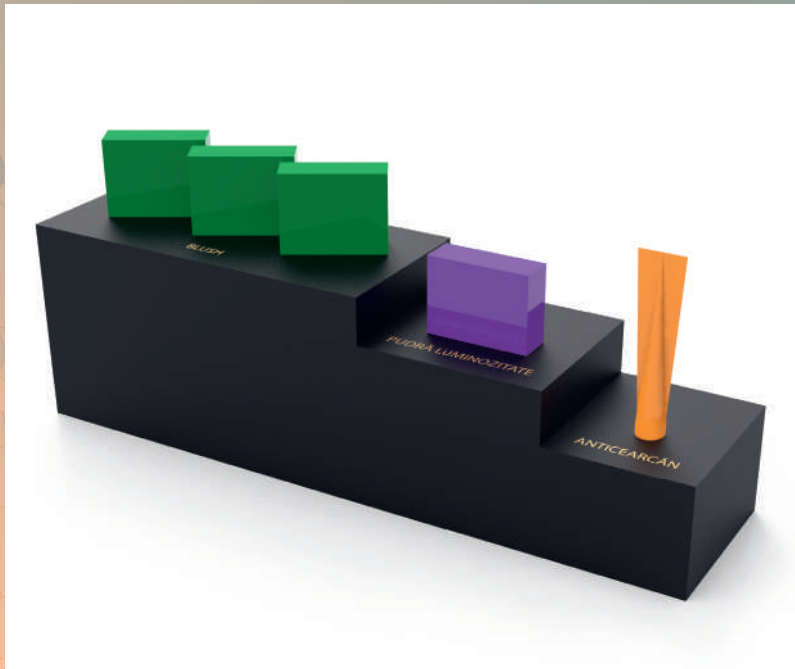
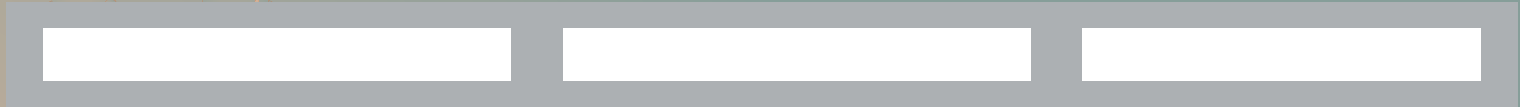

## SMALL COUNTER DISPLAY

### Innovation defines us

All we want is to make your product end up in people's houses. Therefore, we adopt unique and creative ideas to make it happen.

We got this!

### Characteristics:

- Made of plexiglass

# PLEXIGLASS LENS HIGHLIGHTER

An outstanding product needs a tailor-made presentation

No time to despair. We got your back! This product highlighter will fit your product like a glove and it will accentuate all its qualities.

## Characteristics:

- Made of plexiglass (different thicknesses)
- Various sizes

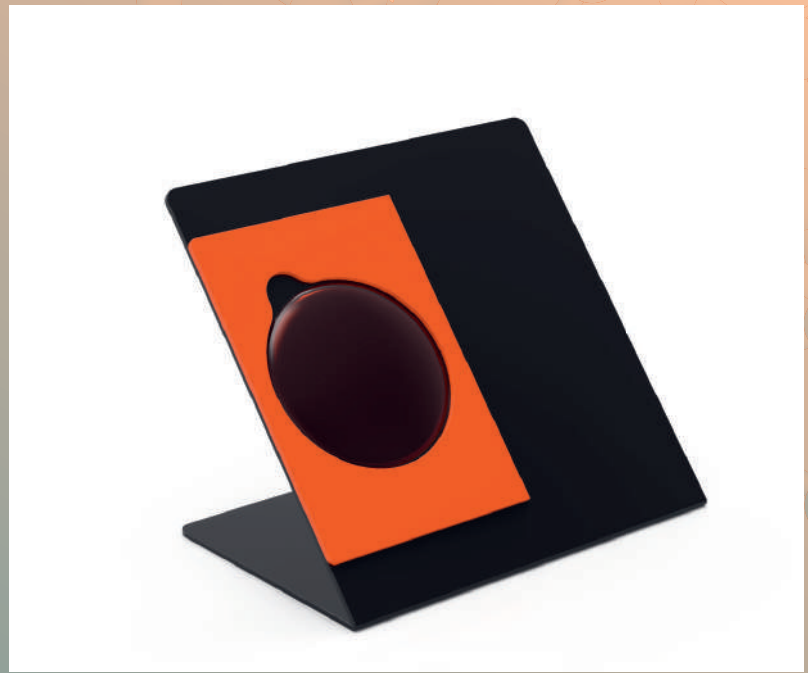





## OPTIC DISPLAYS

**Here's your chance to grab your customers' attention**

This display is a real eye catcher that will showcase all the information needed to encourage the buying behaviour.

### Characteristics:

- Made of PVC foam board and plexiglass
- Various sizes

# A PHARMACY IN A DISPLAY

## Or finding the cardboard limits

A lot of small and delicate products to show, a premium cosmetic brand, a long lifetime, resilient and still delicate display. This was the customer's inquiry.

The result? Classic, nice shapes, solid and space enough to fit a small pharmacy inside. And a lot of engineering, a lot of small parts to assemble.

## Characteristics:

- All UV digital printed cardboard
- Plastic edge finishing
- 50 kg of load to carry

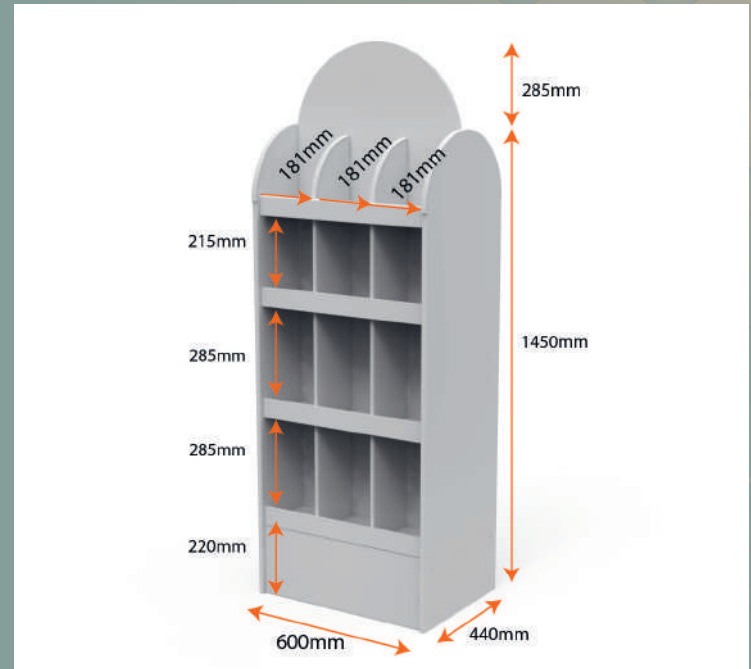

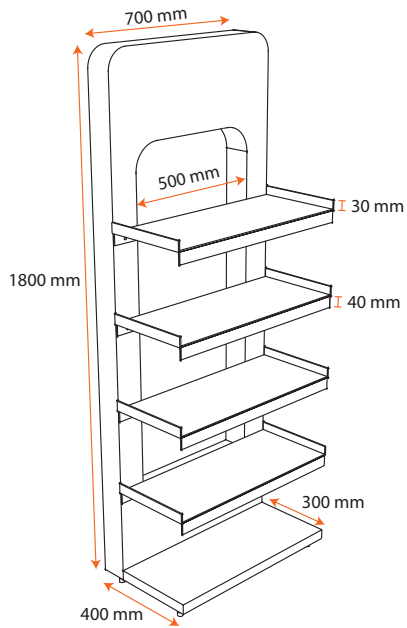

## PREMIUM DISPLAY

**Grab all the attention your product deserves.**

Our premium displays will transform your product into the superstar of the market. The carefully designed details are giving a special touch both to the display and to your product.

### Characteristics:

- Made of chipboard 18 mm and clear plexiglass

# FLOATING AMPOULE

## Actually, wrapped in wood

This customer just developed an innovative anti-aging potion and challenged us to build some floating shelves surrounding the luminous center.

The logo looks like it's painted on air, on top. The light comes from everywhere, from inside the shaped wall, from top and under each shelf. Everything was designed for attraction and eye pleasure.

## Characteristics:

- Made of wood
- Plexiglas and a lot of powerful LED units

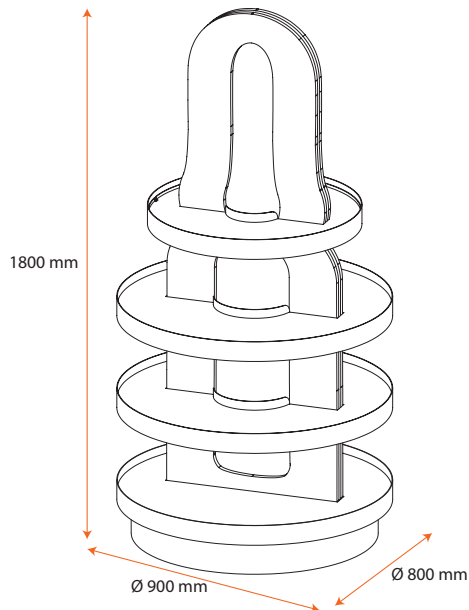

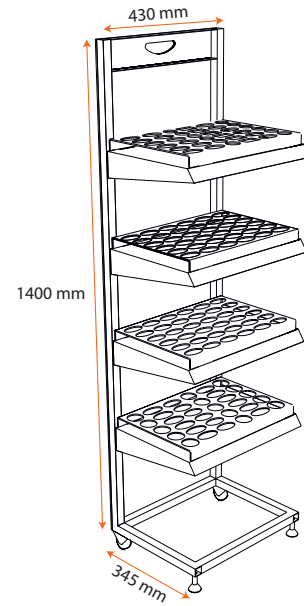

## SLIM METAL DISPLAY

**Slim down, fit better.**

You can fit your display now in really narrow spaces, and yet you will still generate interest in your products.

### **Characteristics:**

- Made of steel sheet, rectangular steel pipe, PVC foam board
- UV printed

# CLASSIC IS FANTASTIC

Do you have the feeling that you've seen this before too?

It's because of the display's old school style, adapted to the nowadays demands. The feeling of deja-vu it's very eye catching and it makes your customers have a closer look.

## Characteristics:

- Metallic structure
- Powder coating
- Double hooks to display a lot of products and wheels for mobility

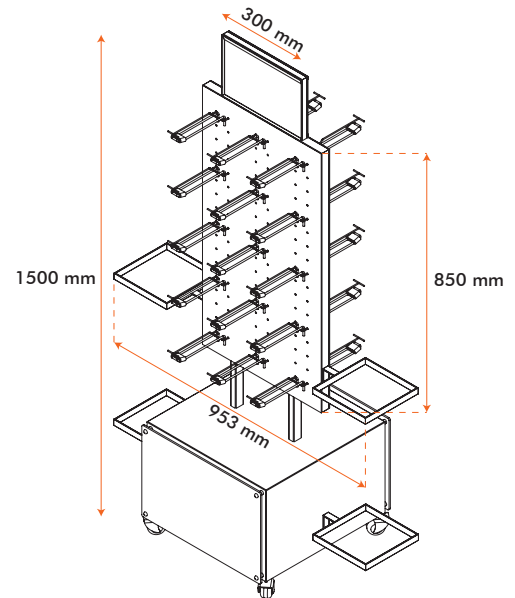
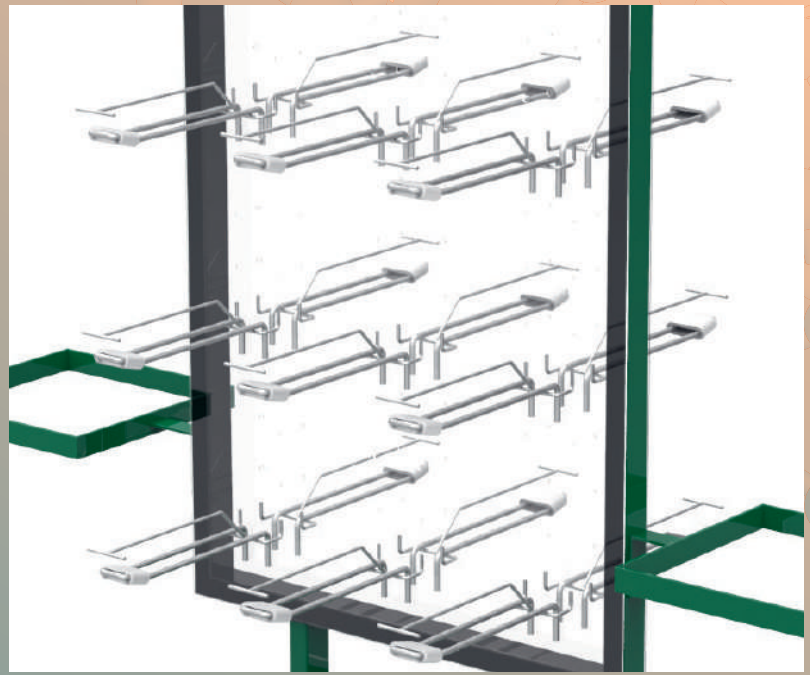



## SHOP IN SHOP DISPLAY

### Stand out from the crowd!

When it comes to the “shop in shop concept”, the competition is quite tight. Therefore, we will make sure your brand will have an outstanding presentation and your customers will remember it.

### Characteristics:

- Made of AL-PVC-AL composite panel, aluminium slatwall profiles, plexiglass, pvc foam board, LED strip and power supply
- Various sizes



## ROMANIA

Customer service, Design, Production  
Calea Șagului (DN59), KM 8+550 m,  
Platforma Incontro, Hala 4-7  
307221 Chișoda, Timiș, Romania  
Phone: +4 0256 305000  
info@artmatch.ro

## ROMANIA

Sales office  
Str. Ecaterina Teodoroiu 5  
010971 București, Sector 1, Romania  
Phone: +40 372783591  
bucuresti@artmatch.ro

## HUNGARY

Kagyló utca 1-3. 2092 Budakeszi  
Phone: +36 23-457145  
info@artmatch.hu

## SERBIA

Bulevar Arsenija Carnojevica 203/3,  
11070 Novi Beograd  
Phone: +381 11-3121575  
info@artmatch.rs

## GERMANY

Raiffeisenring 15, 46395 Bocholt  
Phone: +49 0 2871-2943758  
info@artmatch.net

## MOLDOVA

GO STORE SRL, exclusive distributor  
Str. Zamfir Arbore 6, Chișinău, Moldova  
Phone: +373 22-992822, +373 60-109909  
info@artmatch.md

**ARTMATCH**  
**20**  
years of excellence

[www.artmatch.net](http://www.artmatch.net)

**f** <https://www.facebook.com/artmatch.ro>

**@** [https://www.instagram.com/artmatch\\_timisoara/](https://www.instagram.com/artmatch_timisoara/)

**in** <https://www.linkedin.com/company/art-match/>

**🐦** [https://twitter.com/artmatch\\_ro](https://twitter.com/artmatch_ro)



**ARTMATCH**  
IN EVERY STORE